



NN SERIES

Indoor | Outdoor Rental



Concert & Live Event



School



Hotel



Restaurant & Bar

Product Specifications

Specifications	NN-261	NN-291	NN-391	NN-290	NN-390	NN-480
Pixel Pitch (mm)	2.6	2.9	3.9	2.9	3.9	4.8
LED Type	SMD1515		SMD2121	SMD1415	SMD1921	
Application	Indoor			Outdoor		
Module Size (mm)	250x250					
Module Resolution (pixel)	96X96	84x84	64x64	84x84	64x64	52x52
Cabinet Size (mm)	500x500 / 500x1000					
Cabinet Resolution (pixel)	192x192 / 192x384	168x168 / 168x336	128x128 / 128x256	168x168 / 168x336	128x128 / 128x256	104x104 / 104x208
Brightness (cd/m ²)	700				4000	
Refresh Rate (Hz)	≥3840 / ≥7680					
Contrast Ratio	5000:1					
Gray Scale (Bit)	14					
Power Consumption (W/m ²) Max./Avg.	520 / 260			620 / 310		
Viewing Angle (H/V)	140° / 140°					
Life Span (Hr)	≥100,000					
IP Rate (Front/Back)	IP40 / IP21			IP65 / IP65		
Maintenance Type	Front / Back					
Cabinet Material	Die Casting Aluminum					
Cabinet Weight (Kg)	6 / 11			6.5 / 12		
Curve	±5°, ±10°, ±15°, 90°					
Installation	Hanging / Stacking					

Key Features

Module & Box Design, Quick Maintenance

- LED module, power box is independent unit, simple and quick maintenance

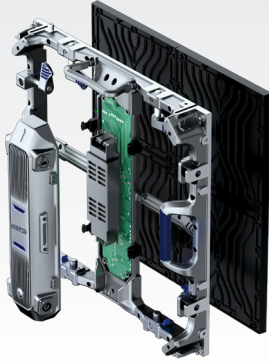

Ultrahigh $\geq 7680\text{Hz}$ Refresh Rate (Optional)

- Super high refresh rate for vivid playing effect



Anti-damage System

- Strong soldering point
- Angle protector design

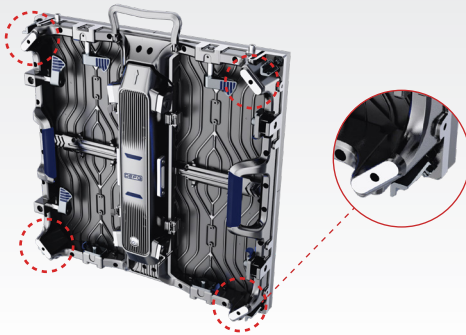

Curve & Cube Options for More Shape

- Optional curve lock design at $\pm 5^\circ$, $\pm 10^\circ$, $\pm 15^\circ$, 90°

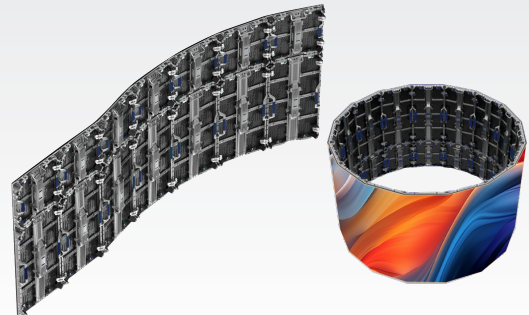

Fast & Safe Installation

- Fast locks design
- Locating pins design

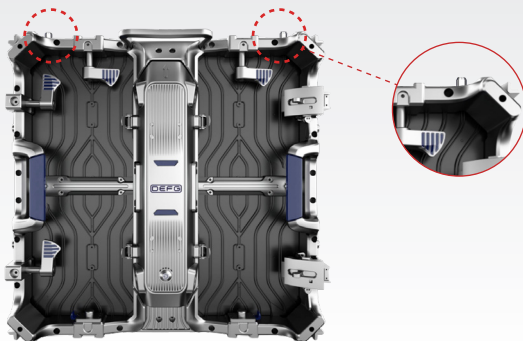

Quick ROI

- Experience rapid return on investment, ensuring profitability in shorter time

